

PRODUCT:	ELI 600 CENTRE
SIZE:	600W x 500D x *562/570H
CONFIGURATION:	ALL-DRAWER, WALL HUNG
VERSION: 01	DATE: 25/09/2024

TOP:	40MM BENCHTOP
BASIN POSITION:	CENTRE
CODE:	ELIFAW0600WHC** CODE SUFFIX DEPENDENT ON BENCHTOP MATERIAL SEE BROCHURE OR ADPAUSTRALIA.COM.AU FOR DETAILS

NOTES:	DIMENSIONS ARE NOMINAL. DO NOT DRILL OR ROUGH IN UNTIL YOU HAVE RECEIVED AND MEASURED YOUR VANITY. ALL DIMENSIONS ARE IN MILLIMETRES. DO NOT MEASURE FROM DRAWING. *FOR DURASEIN FINISHES 12MM MATERIAL THICKNESS. 20MM THICKNESS FOR ALL OTHER BENCHTOP FINISHES.
--------	--

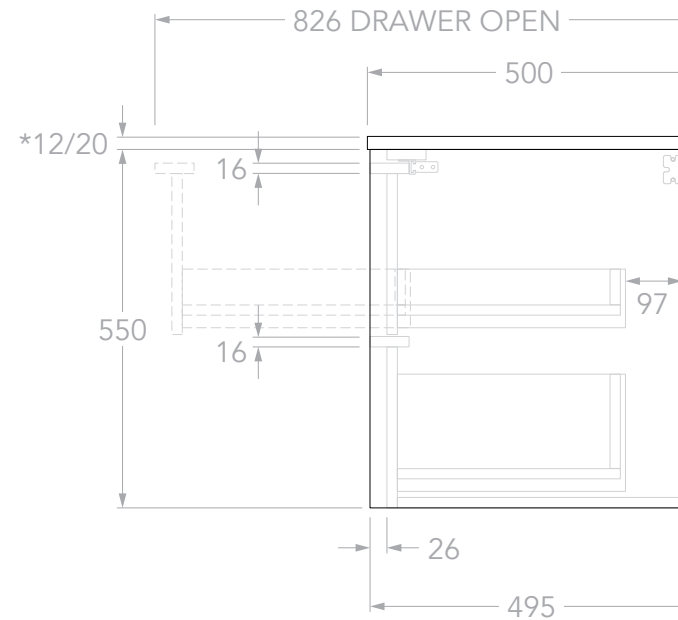
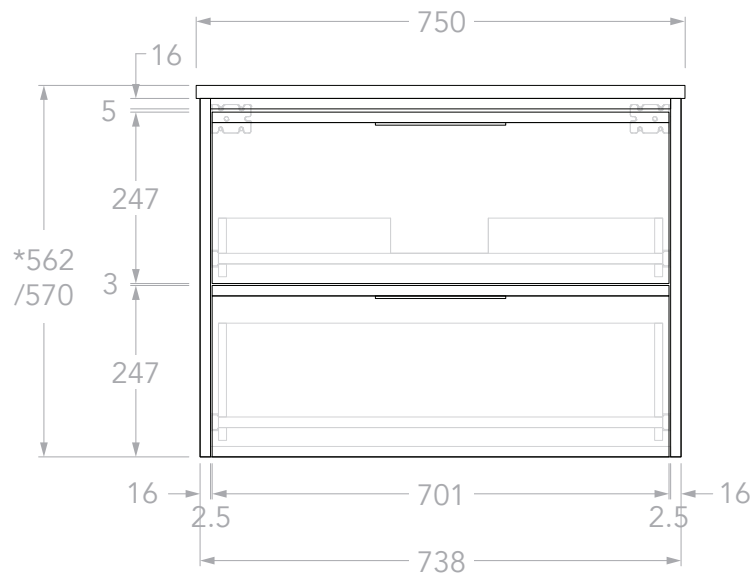
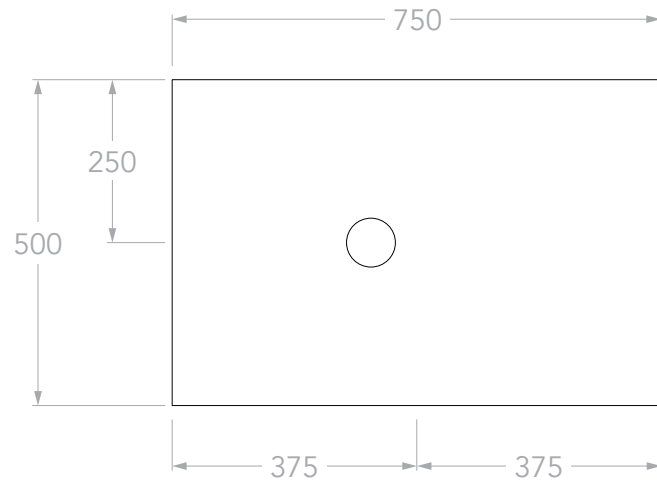

PRODUCT:	ELI 750 CENTRE
SIZE:	750W x 500D x *562/570H
CONFIGURATION:	ALL-DRAWER, WALL HUNG
VERSION: 01	DATE: 25/09/2024

TOP:	40MM BENCHTOP
BASIN POSITION:	CENTRE
CODE:	ELIFAW0750WHC** CODE SUFFIX DEPENDENT ON BENCHTOP MATERIAL SEE BROCHURE OR ADPAUSTRALIA.COM.AU FOR DETAILS

NOTES:	DIMENSIONS ARE NOMINAL. DO NOT DRILL OR ROUGH IN UNTIL YOU HAVE RECEIVED AND MEASURED YOUR VANITY. ALL DIMENSIONS ARE IN MILLIMETRES. DO NOT MEASURE FROM DRAWING. *FOR DURASEIN FINISHES 12MM MATERIAL THICKNESS. 20MM THICKNESS FOR ALL OTHER BENCHTOP FINISHES.
--------	--

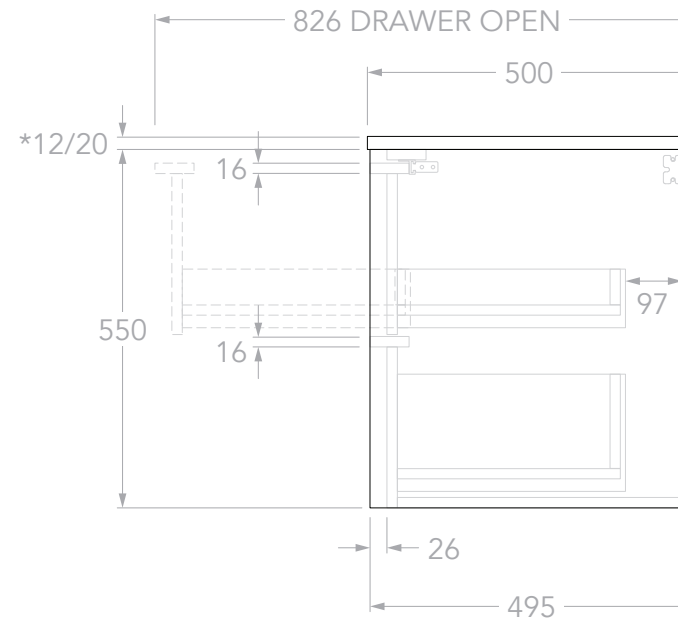
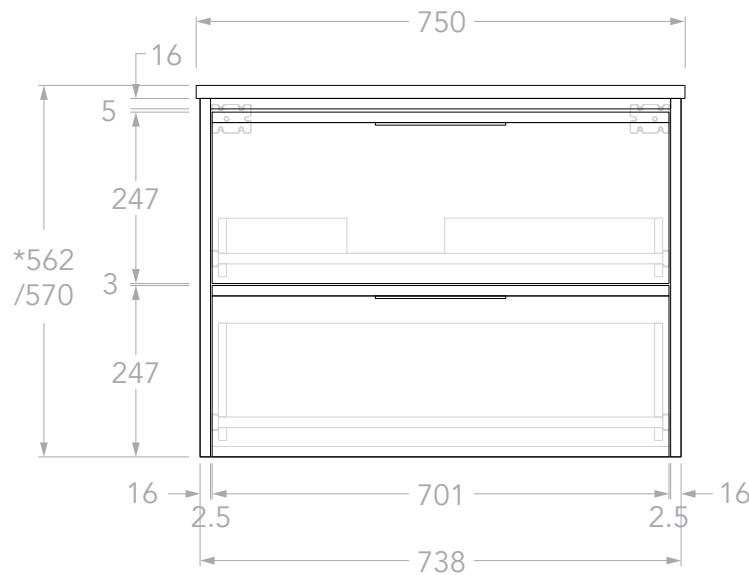
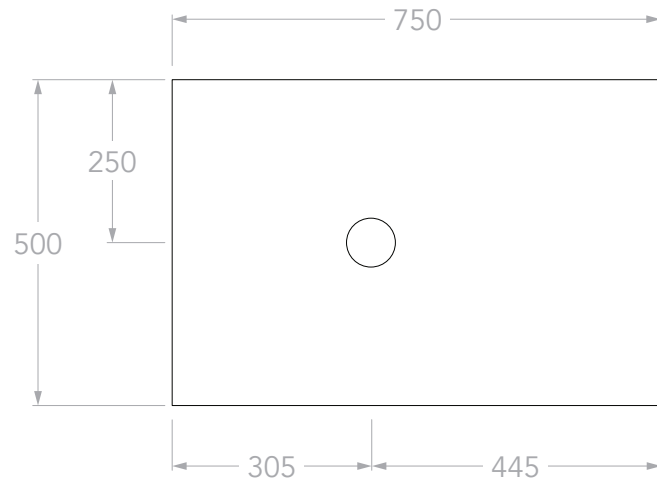

PRODUCT:	ELI 750 LEFT
SIZE:	750W x 500D x *562/570H
CONFIGURATION:	ALL-DRAWER, WALL HUNG
VERSION: 01	DATE: 25/09/2024

TOP:	40MM BENCHTOP
BASIN POSITION:	LEFT
CODE:	ELIFAW0750WHL** CODE SUFFIX DEPENDENT ON BENCHTOP MATERIAL SEE BROCHURE OR ADPAUSTRALIA.COM.AU FOR DETAILS

NOTES:	DIMENSIONS ARE NOMINAL. DO NOT DRILL OR ROUGH IN UNTIL YOU HAVE RECEIVED AND MEASURED YOUR VANITY. ALL DIMENSIONS ARE IN MILLIMETRES. DO NOT MEASURE FROM DRAWING. *FOR DURASEIN FINISHES 12MM MATERIAL THICKNESS. 20MM THICKNESS FOR ALL OTHER BENCHTOP FINISHES.
--------	--

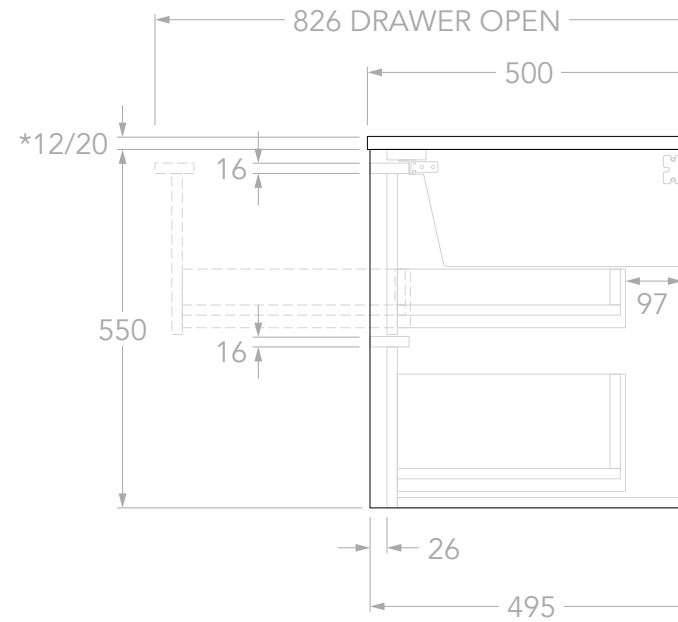
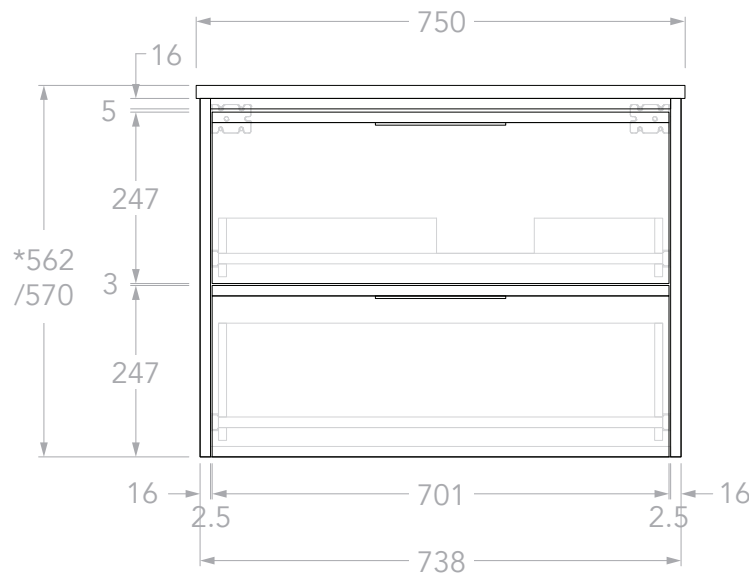
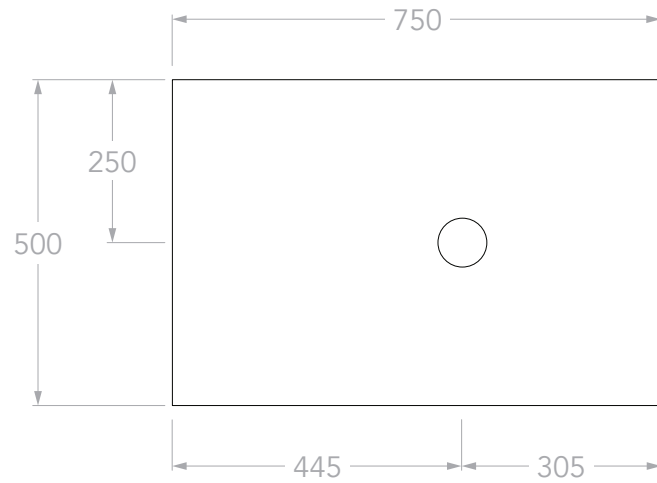

PRODUCT:	ELI 750 RIGHT
SIZE:	750W x 500D x *562/570H
CONFIGURATION:	ALL-DRAWER, WALL HUNG
VERSION: 01	DATE: 25/09/2024

TOP:	40MM BENCHTOP
BASIN POSITION:	RIGHT
CODE:	ELIFAW0750WHR** CODE SUFFIX DEPENDENT ON BENCHTOP MATERIAL SEE BROCHURE OR ADPAUSTRALIA.COM.AU FOR DETAILS

NOTES:	DIMENSIONS ARE NOMINAL. DO NOT DRILL OR ROUGH IN UNTIL YOU HAVE RECIEVED AND MEASURED YOUR VANITY. ALL DIMENSIONS ARE IN MILLIMETRES. DO NOT MEASURE FROM DRAWING. *FOR DURASEIN FINISHES 12MM MATERIAL THICKNESS. 20MM THICKNESS FOR ALL OTHER BENCHTOP FINISHES.
--------	--

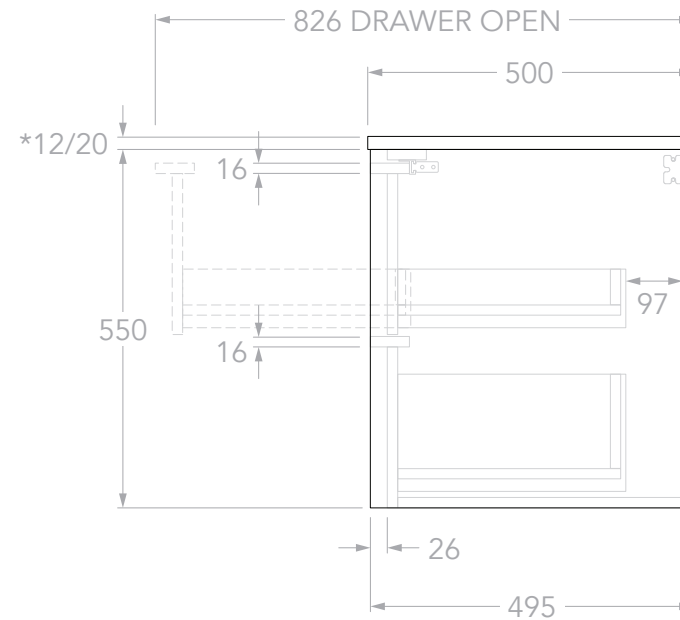
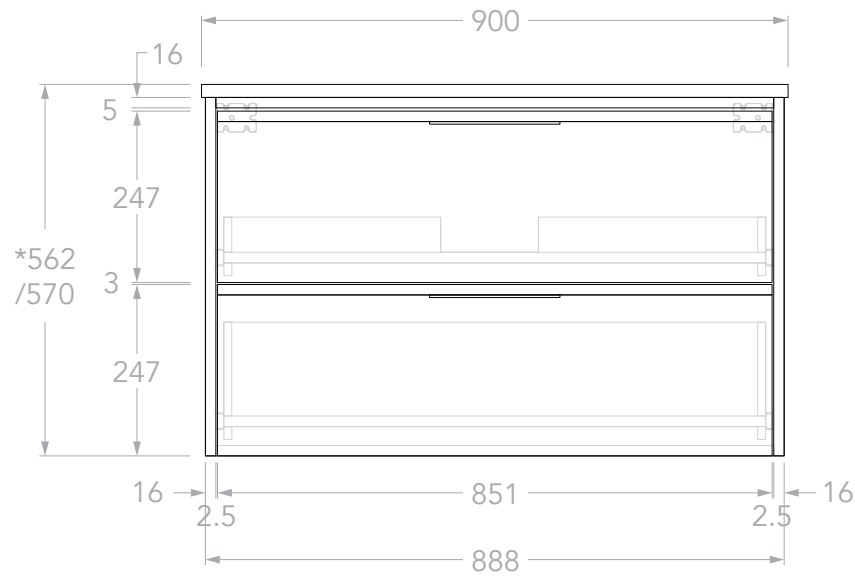
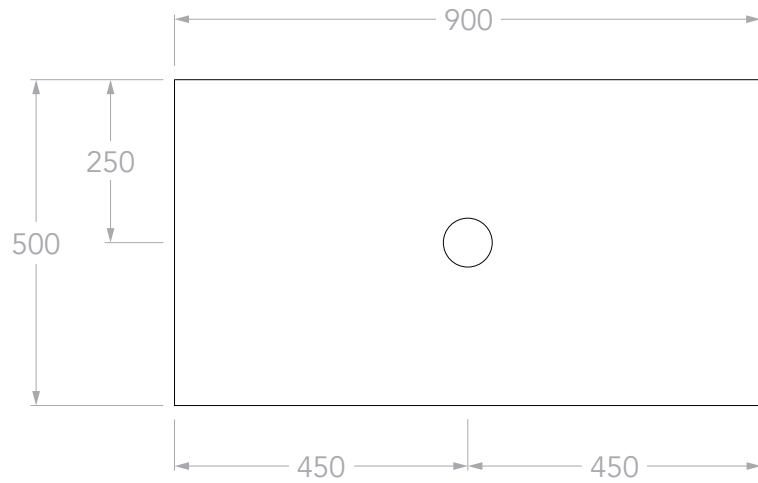

PRODUCT:	ELI 900 CENTRE
SIZE:	900W x 500D x *562/570H
CONFIGURATION:	ALL-DRAWER, WALL HUNG
VERSION: 01	DATE: 25/09/2024

TOP:	40MM BENCHTOP
BASIN POSITION:	CENTRE
CODE:	ELIFAW0900WHC** CODE SUFFIX DEPENDENT ON BENCHTOP MATERIAL SEE BROCHURE OR ADPAUSTRALIA.COM.AU FOR DETAILS

NOTES:	DIMENSIONS ARE NOMINAL. DO NOT DRILL OR ROUGH IN UNTIL YOU HAVE RECEIVED AND MEASURED YOUR VANITY. ALL DIMENSIONS ARE IN MILLIMETRES. DO NOT MEASURE FROM DRAWING. *FOR DURASEIN FINISHES 12MM MATERIAL THICKNESS. 20MM THICKNESS FOR ALL OTHER BENCHTOP FINISHES.
--------	--

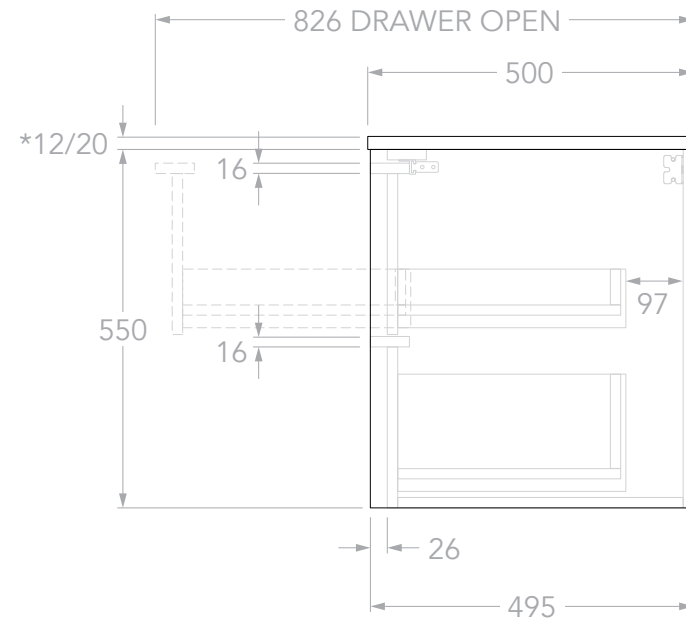
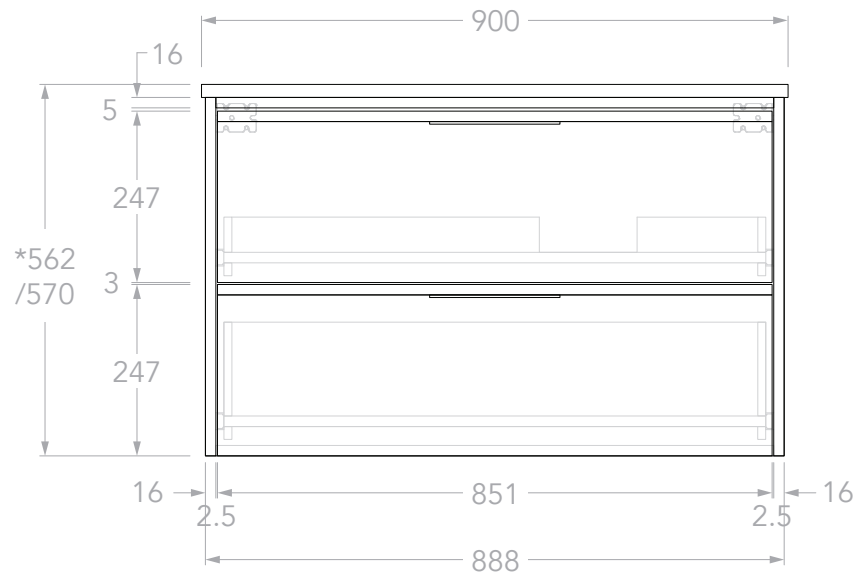
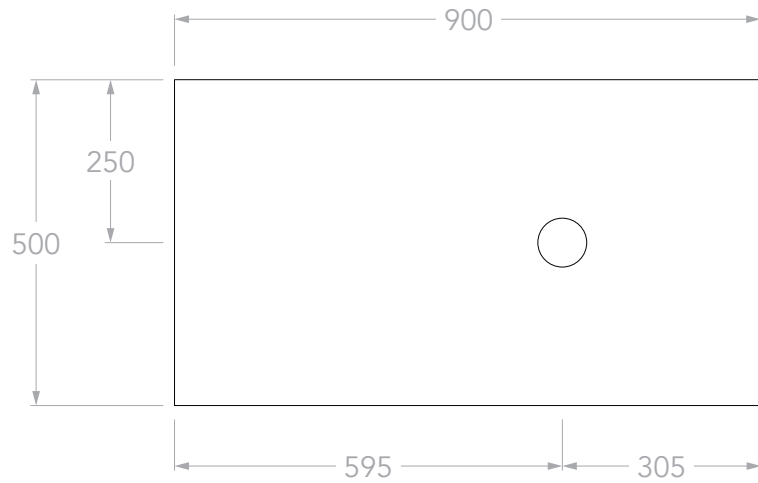

PRODUCT:	ELI 900 RIGHT
SIZE:	900W x 500D x *562/570H
CONFIGURATION:	ALL-DRAWER, WALL HUNG
VERSION: 01	DATE: 25/09/2024

TOP:	40MM BENCHTOP
BASIN POSITION:	RIGHT
CODE:	ELIFAW0900WHR** CODE SUFFIX DEPENDENT ON BENCHTOP MATERIAL SEE BROCHURE OR ADPAUSTRALIA.COM.AU FOR DETAILS

NOTES:	DIMENSIONS ARE NOMINAL. DO NOT DRILL OR ROUGH IN UNTIL YOU HAVE RECIEVED AND MEASURED YOUR VANITY. ALL DIMENSIONS ARE IN MILLIMETRES. DO NOT MEASURE FROM DRAWING. *FOR DURASEIN FINISHES 12MM MATERIAL THICKNESS. 20MM THICKNESS FOR ALL OTHER BENCHTOP FINISHES.
--------	--

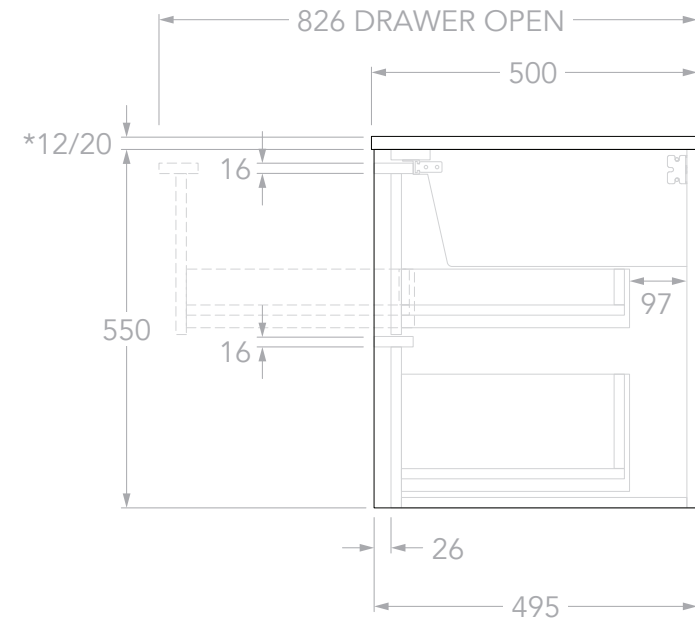
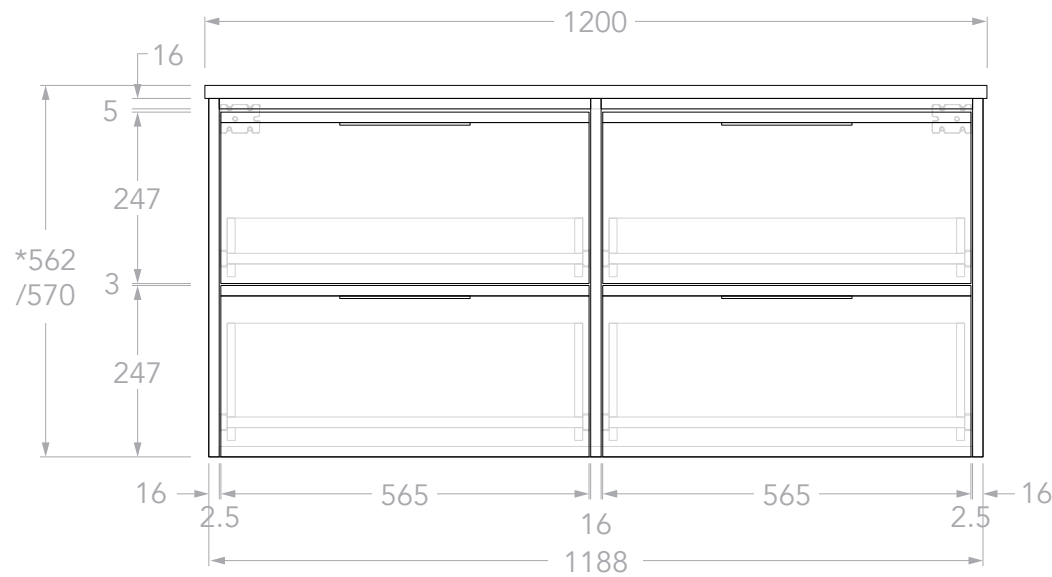
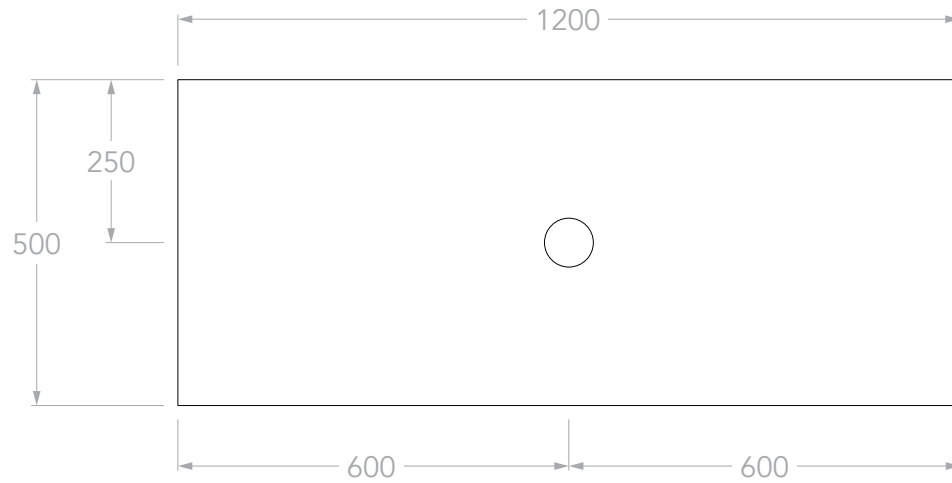

PRODUCT:	ELI 1200 CENTRE
SIZE:	1200W x 500D x *562/570H
CONFIGURATION:	ALL-DRAWER, WALL HUNG
VERSION: 01	DATE: 25/09/2024

TOP:	40MM BENCHTOP
BASIN POSITION:	CENTRE
CODE:	ELIFAW1200WHC** CODE SUFFIX DEPENDENT ON BENCHTOP MATERIAL SEE BROCHURE OR ADPAUSTRALIA.COM.AU FOR DETAILS

NOTES:	DIMENSIONS ARE NOMINAL. DO NOT DRILL OR ROUGH IN UNTIL YOU HAVE RECEIVED AND MEASURED YOUR VANITY. ALL DIMENSIONS ARE IN MILLIMETRES. DO NOT MEASURE FROM DRAWING. *FOR DURASEIN FINISHES 12MM MATERIAL THICKNESS. 20MM THICKNESS FOR ALL OTHER BENCHTOP FINISHES.
--------	--

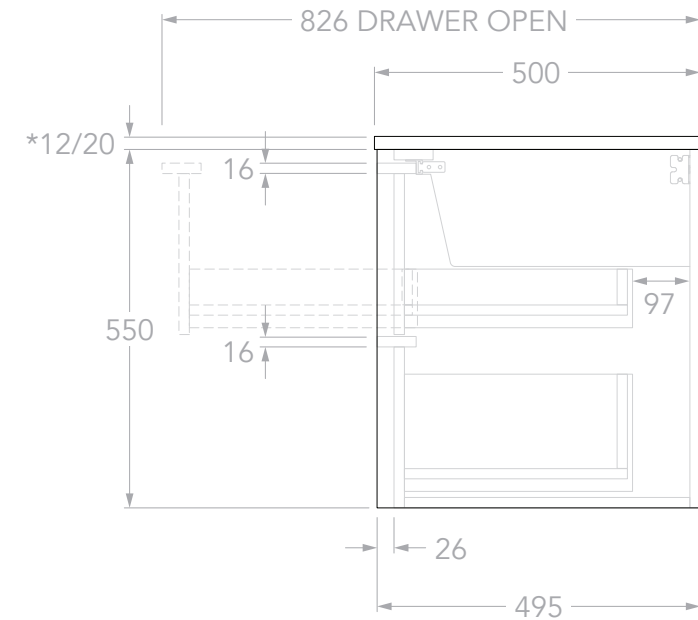
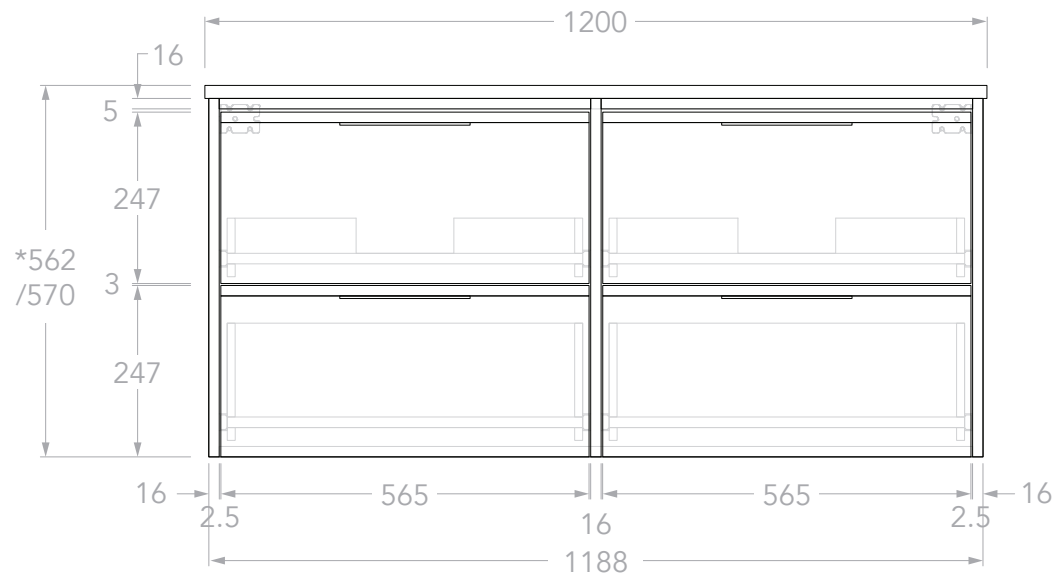
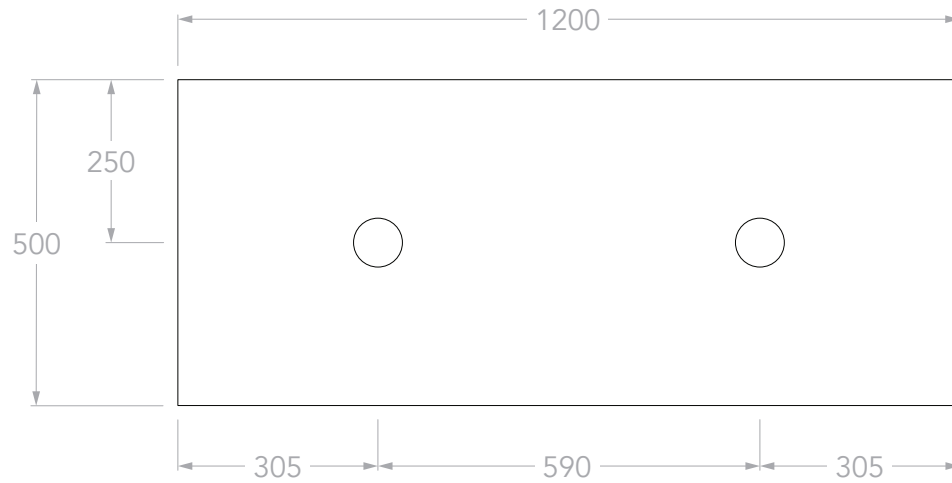

PRODUCT:	ELI 1200 DOUBLE
SIZE:	1200W x 500D x *562/570H
CONFIGURATION:	ALL-DRAWER, WALL HUNG
VERSION: 01	DATE: 25/09/2024

TOP:	40MM BENCHTOP
BASIN POSITION:	DOUBLE
CODE:	ELIFAW1200WHD** CODE SUFFIX DEPENDENT ON BENCHTOP MATERIAL SEE BROCHURE OR ADPAUSTRALIA.COM.AU FOR DETAILS

NOTES:	DIMENSIONS ARE NOMINAL. DO NOT DRILL OR ROUGH IN UNTIL YOU HAVE RECEIVED AND MEASURED YOUR VANITY. ALL DIMENSIONS ARE IN MILLIMETRES. DO NOT MEASURE FROM DRAWING. *FOR DURASEIN FINISHES 12MM MATERIAL THICKNESS. 20MM THICKNESS FOR ALL OTHER BENCHTOP FINISHES.
--------	--

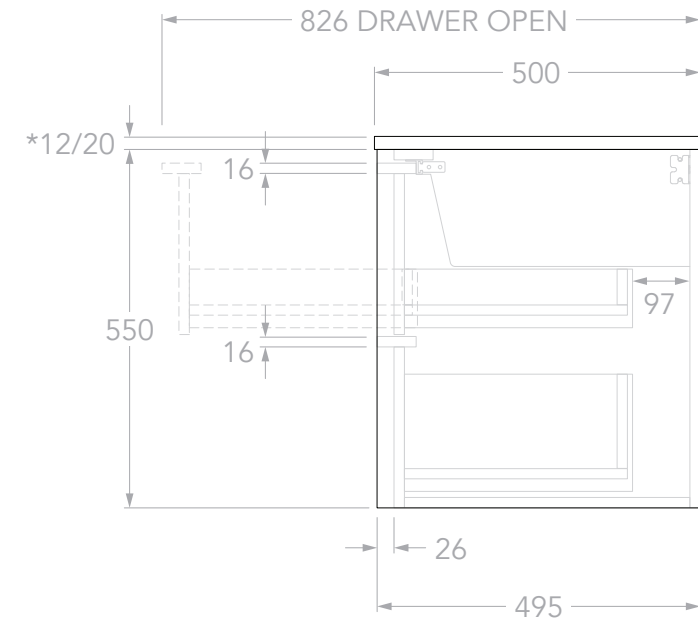
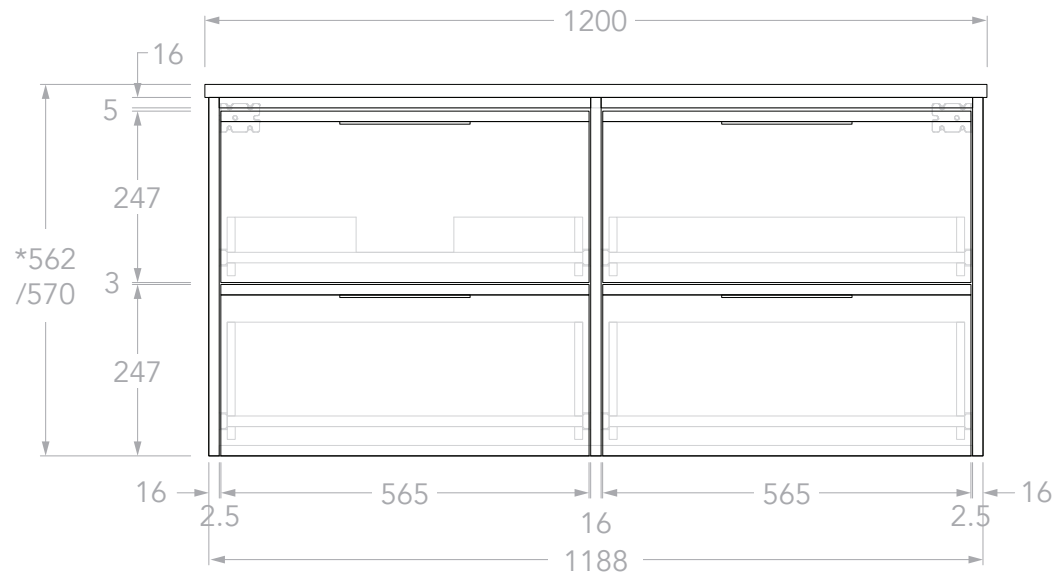
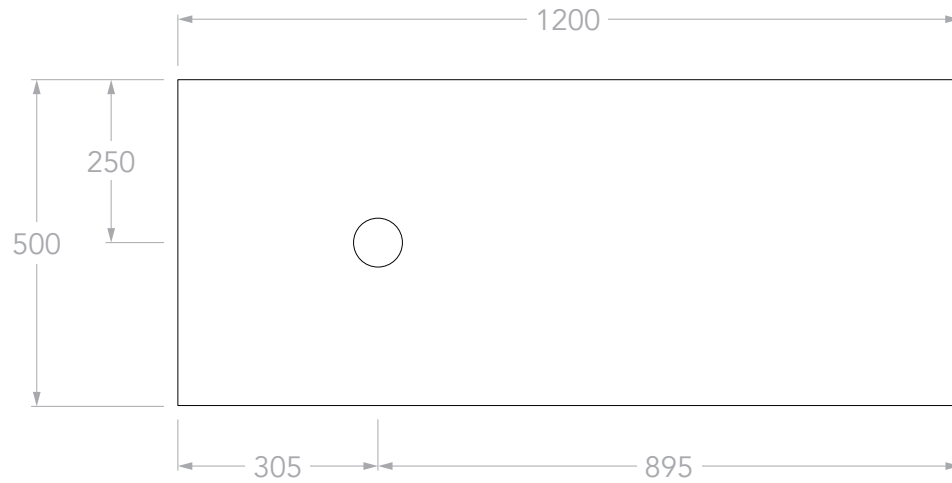

PRODUCT:	ELI 1200 LEFT
SIZE:	1200W x 500D x *562/570H
CONFIGURATION:	ALL-DRAWER, WALL HUNG
VERSION: 01	DATE: 25/09/2024

TOP:	40MM BENCHTOP
BASIN POSITION:	LEFT
CODE:	ELIFAW1200WHL** CODE SUFFIX DEPENDENT ON BENCHTOP MATERIAL SEE BROCHURE OR ADPAUSTRALIA.COM.AU FOR DETAILS

NOTES:	DIMENSIONS ARE NOMINAL. DO NOT DRILL OR ROUGH IN UNTIL YOU HAVE RECEIVED AND MEASURED YOUR VANITY. ALL DIMENSIONS ARE IN MILLIMETRES. DO NOT MEASURE FROM DRAWING. *FOR DURASEIN FINISHES 12MM MATERIAL THICKNESS. 20MM THICKNESS FOR ALL OTHER BENCHTOP FINISHES.
--------	--

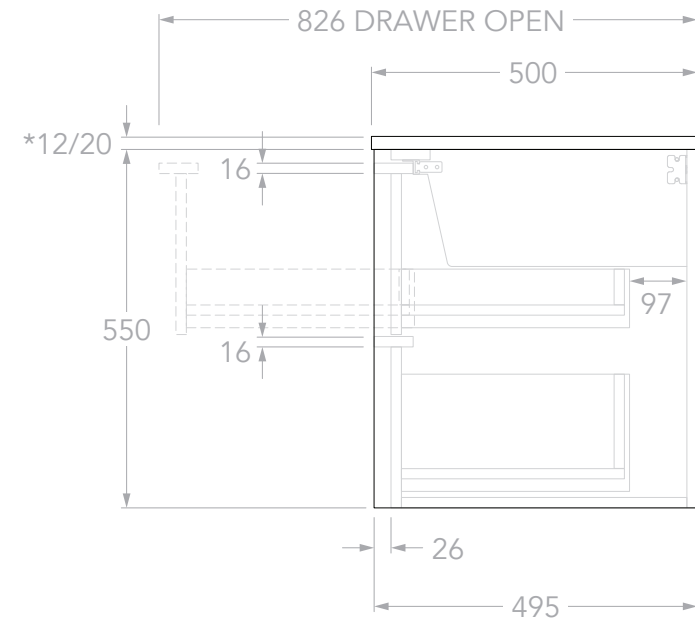
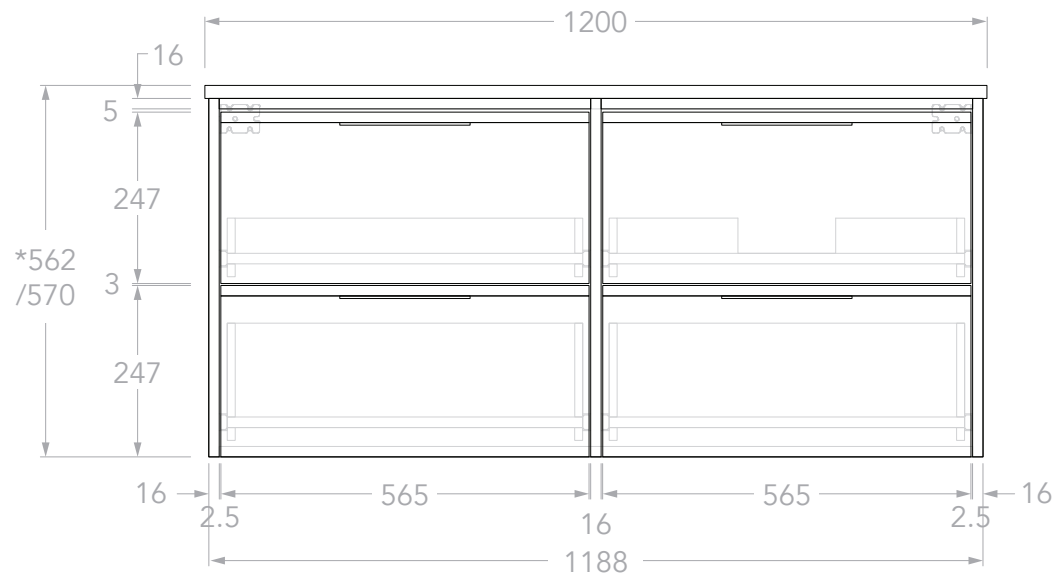

PRODUCT:	ELI 1200 RIGHT
SIZE:	1200W x 500D x *562/570H
CONFIGURATION:	ALL-DRAWER, WALL HUNG
VERSION: 01	DATE: 25/09/2024

TOP:	40MM BENCHTOP
BASIN POSITION:	RIGHT
CODE:	ELIFAW1200WHR** CODE SUFFIX DEPENDENT ON BENCHTOP MATERIAL SEE BROCHURE OR ADPAUSTRALIA.COM.AU FOR DETAILS

NOTES:	DIMENSIONS ARE NOMINAL. DO NOT DRILL OR ROUGH IN UNTIL YOU HAVE RECEIVED AND MEASURED YOUR VANITY. ALL DIMENSIONS ARE IN MILLIMETRES. DO NOT MEASURE FROM DRAWING. *FOR DURASEIN FINISHES 12MM MATERIAL THICKNESS. 20MM THICKNESS FOR ALL OTHER BENCHTOP FINISHES.
--------	--

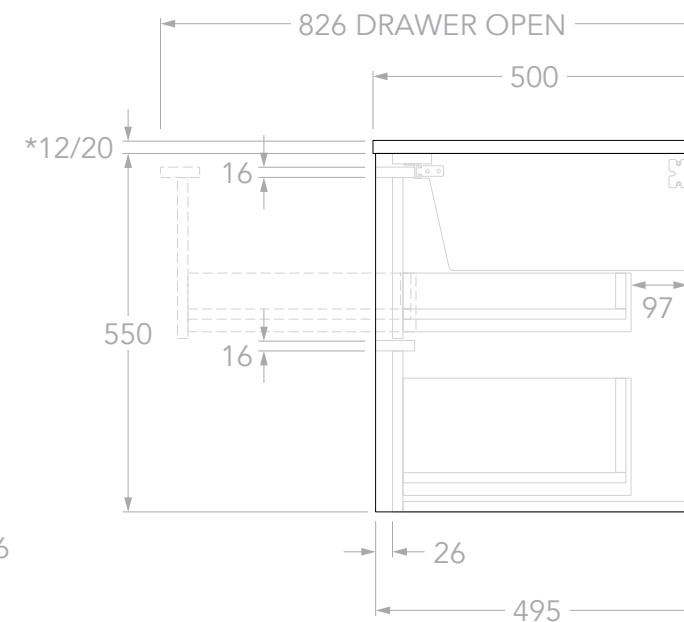
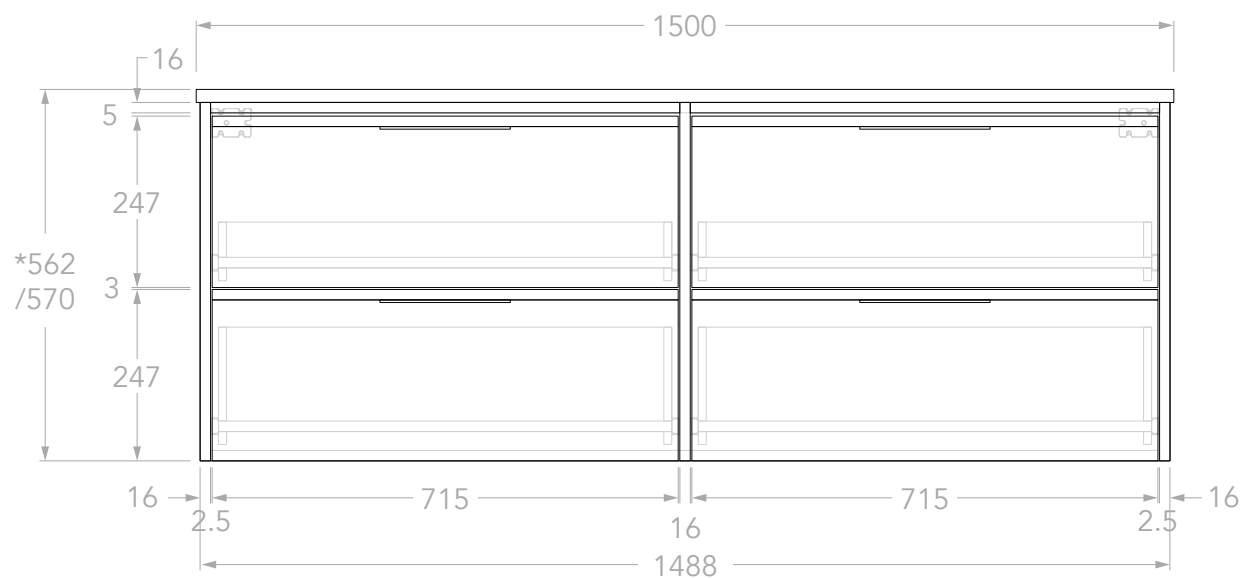
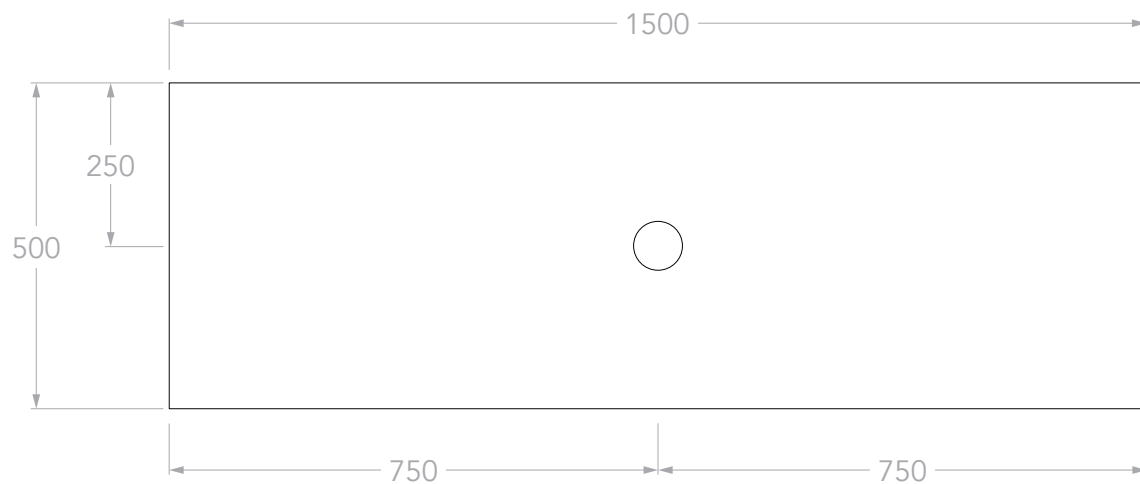

PRODUCT:	ELI 1500 CENTRE
SIZE:	1500W x 500D x *562/570H
CONFIGURATION:	ALL-DRAWER, WALL HUNG
VERSION: 01	DATE: 25/09/2024

TOP:	40MM BENCHTOP
BASIN POSITION:	CENTRE
CODE:	ELIFAW1500WHC** CODE SUFFIX DEPENDENT ON BENCHTOP MATERIAL SEE BROCHURE OR ADPAUSTRALIA.COM.AU FOR DETAILS

NOTES:	DIMENSIONS ARE NOMINAL. DO NOT DRILL OR ROUGH IN UNTIL YOU HAVE RECEIVED AND MEASURED YOUR VANITY. ALL DIMENSIONS ARE IN MILLIMETRES. DO NOT MEASURE FROM DRAWING. *FOR DURASEIN FINISHES 12MM MATERIAL THICKNESS. 20MM THICKNESS FOR ALL OTHER BENCHTOP FINISHES.
--------	--

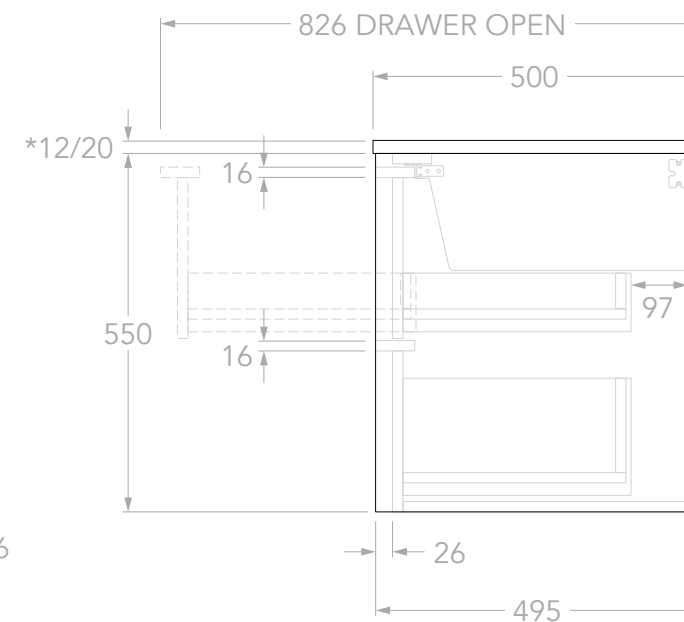
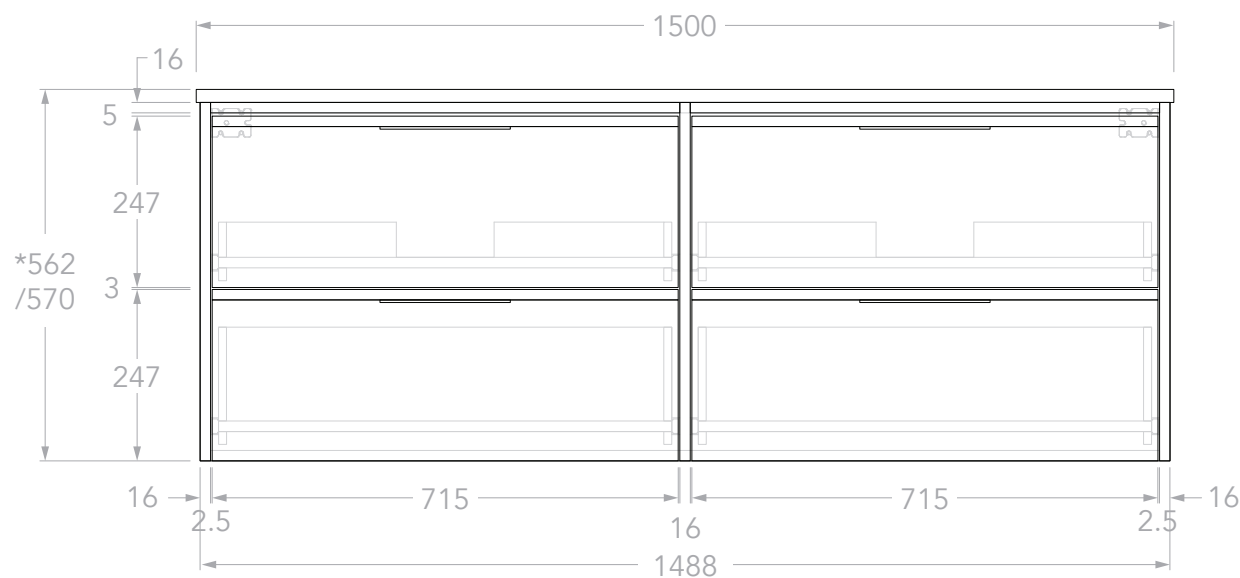
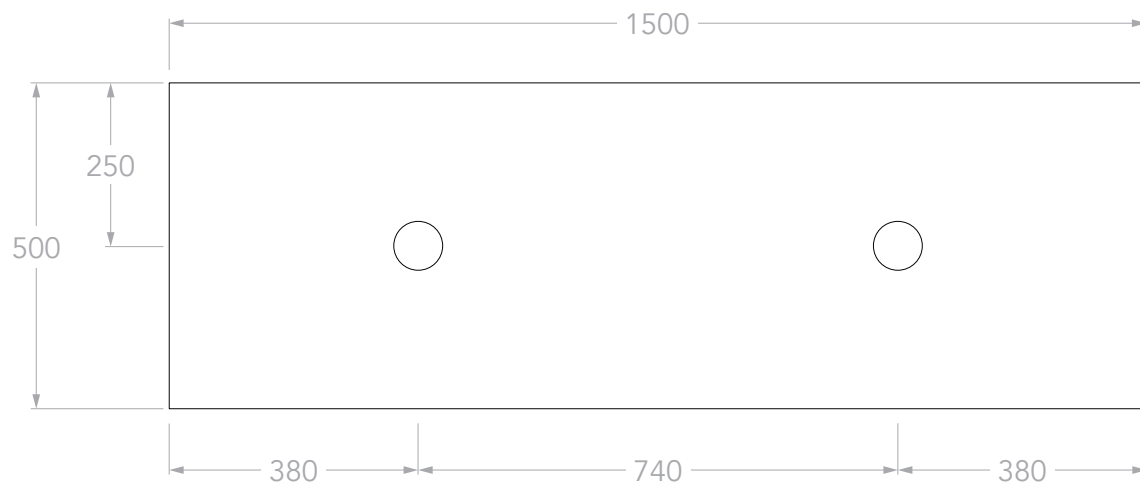

Adp

PRODUCT:	ELI 1500 DOUBLE
SIZE:	1500W x 500D x *562/570H
CONFIGURATION:	ALL-DRAWER, WALL HUNG
VERSION: 01	DATE: 25/09/2024

TOP:	40MM BENCHTOP
BASIN POSITION:	DOUBLE
CODE:	ELIFAW1500WHC** CODE SUFFIX DEPENDENT ON BENCHTOP MATERIAL SEE BROCHURE OR ADPAUSTRALIA.COM.AU FOR DETAILS

NOTES:	DIMENSIONS ARE NOMINAL. DO NOT DRILL OR ROUGH IN UNTIL YOU HAVE RECEIVED AND MEASURED YOUR VANITY. ALL DIMENSIONS ARE IN MILLIMETRES. DO NOT MEASURE FROM DRAWING. *FOR DURASEIN FINISHES 12MM MATERIAL THICKNESS. 20MM THICKNESS FOR ALL OTHER BENCHTOP FINISHES.
--------	--

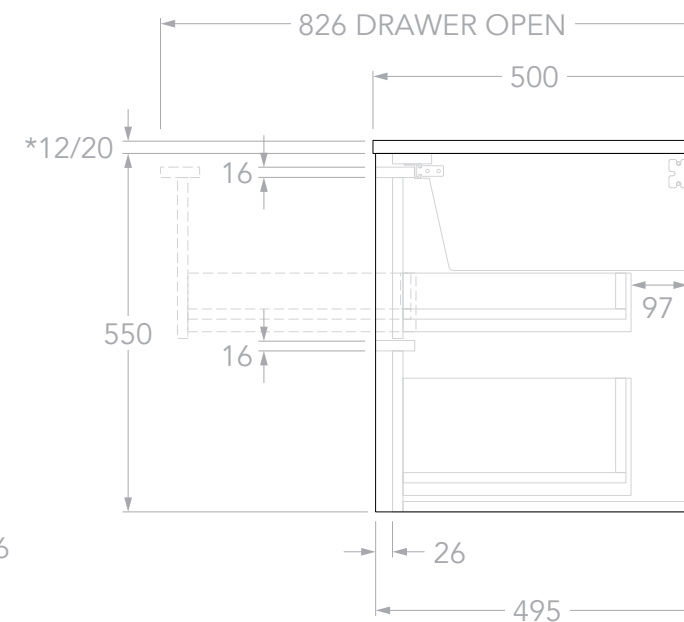
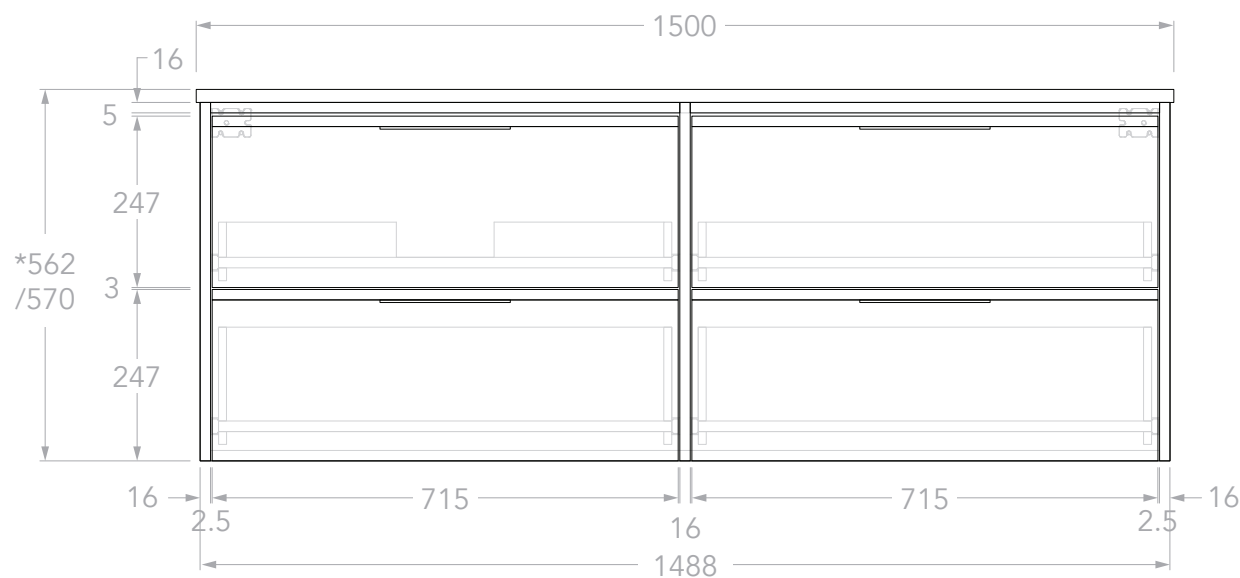
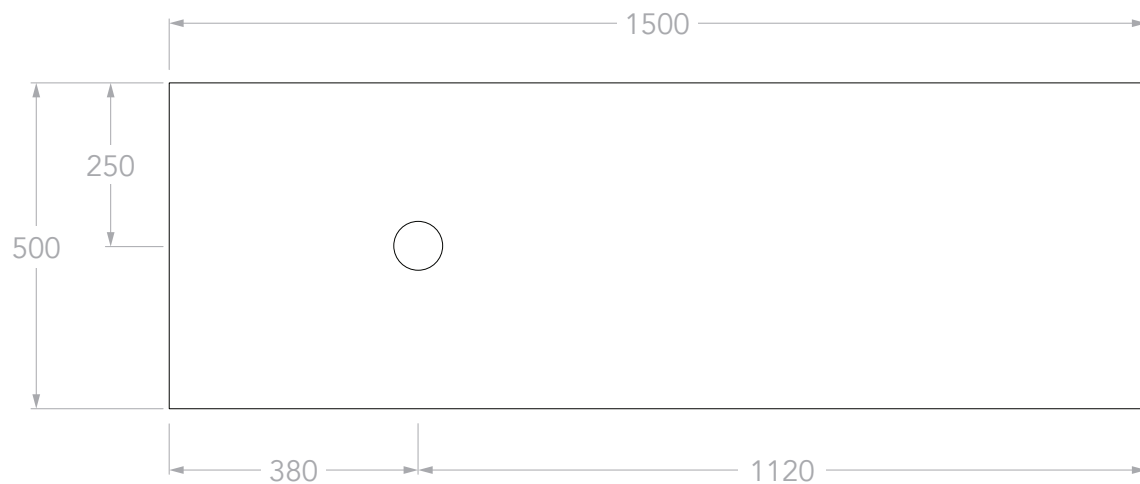

Adp

PRODUCT:	ELI 1500 LEFT
SIZE:	1500W x 500D x *562/570H
CONFIGURATION:	ALL-DRAWER, WALL HUNG
VERSION: 01	DATE: 25/09/2024

TOP:	40MM BENCHTOP
BASIN POSITION:	LEFT
CODE:	ELIFAW1500WHL** CODE SUFFIX DEPENDENT ON BENCHTOP MATERIAL SEE BROCHURE OR ADPAUSTRALIA.COM.AU FOR DETAILS

NOTES:	DIMENSIONS ARE NOMINAL. DO NOT DRILL OR ROUGH IN UNTIL YOU HAVE RECEIVED AND MEASURED YOUR VANITY. ALL DIMENSIONS ARE IN MILLIMETRES. DO NOT MEASURE FROM DRAWING. *FOR DURASEIN FINISHES 12MM MATERIAL THICKNESS. 20MM THICKNESS FOR ALL OTHER BENCHTOP FINISHES.
--------	--

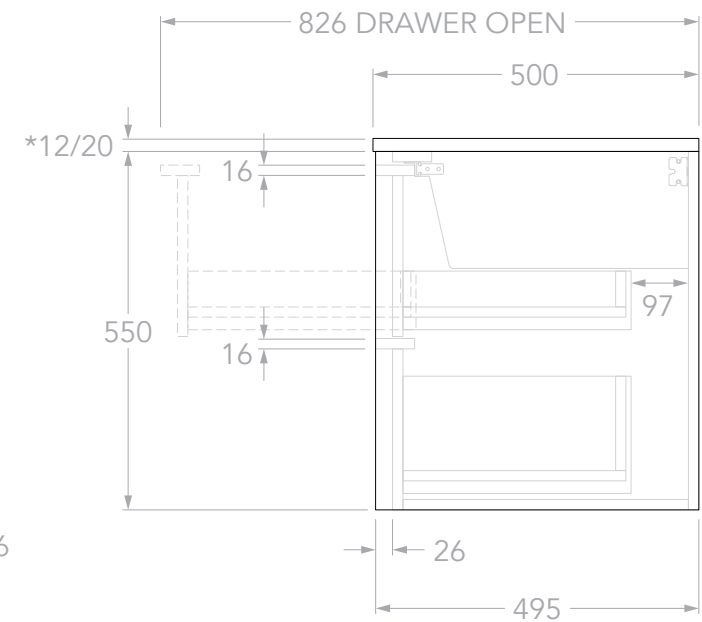
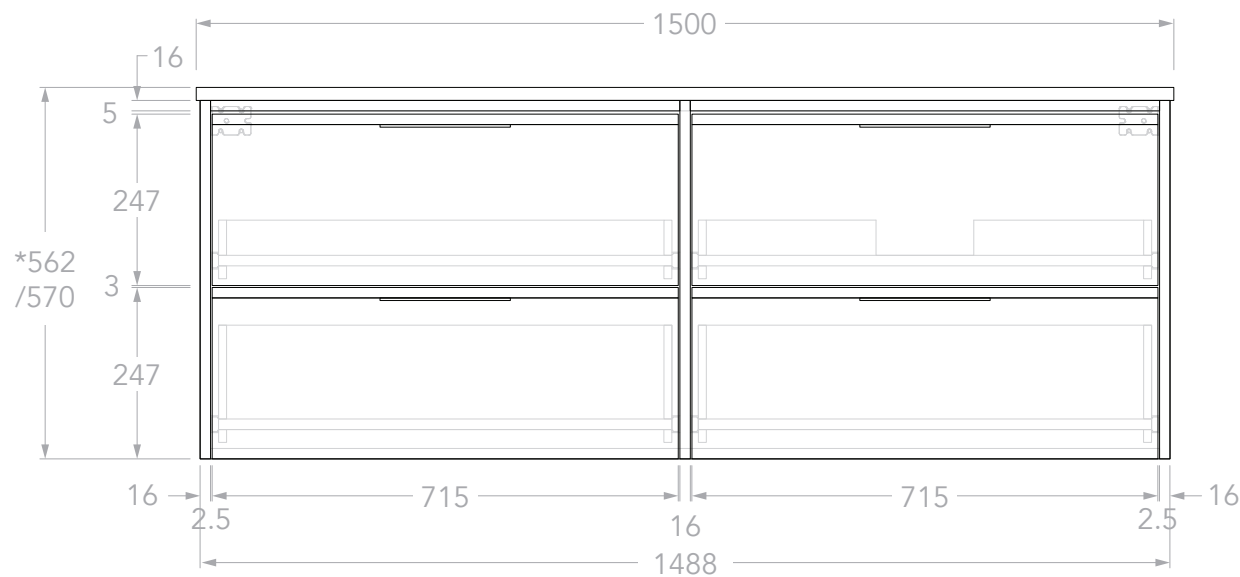
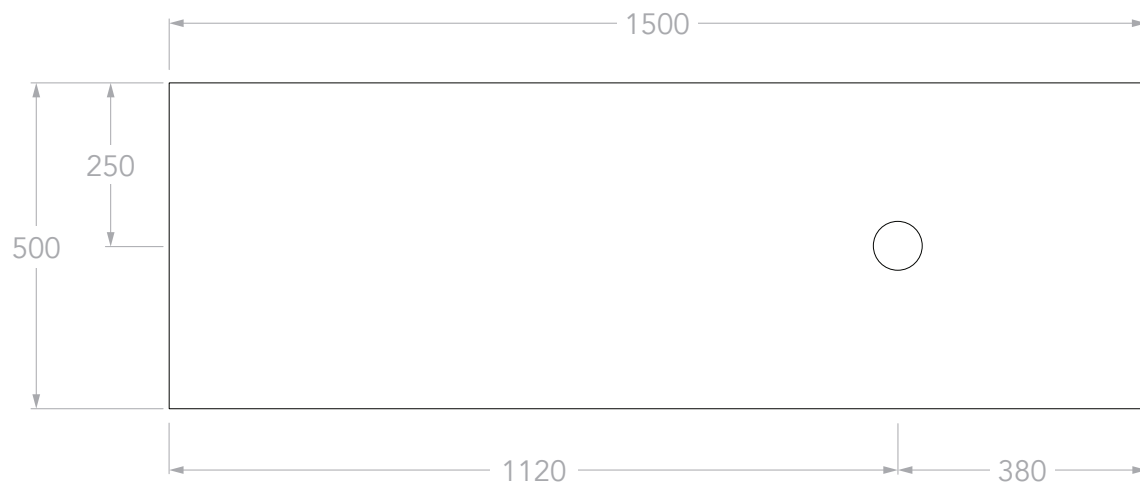

PRODUCT:	ELI 1500 RIGHT
SIZE:	1500W x 500D x *562/570H
CONFIGURATION:	ALL-DRAWER, WALL HUNG
VERSION: 01	DATE: 25/09/2024

TOP:	40MM BENCHTOP
BASIN POSITION:	RIGHT
CODE:	ELIFAW1500WHR** CODE SUFFIX DEPENDENT ON BENCHTOP MATERIAL SEE BROCHURE OR ADPAUSTRALIA.COM.AU FOR DETAILS

NOTES:	DIMENSIONS ARE NOMINAL. DO NOT DRILL OR ROUGH IN UNTIL YOU HAVE RECEIVED AND MEASURED YOUR VANITY. ALL DIMENSIONS ARE IN MILLIMETRES. DO NOT MEASURE FROM DRAWING. *FOR DURASEIN FINISHES 12MM MATERIAL THICKNESS. 20MM THICKNESS FOR ALL OTHER BENCHTOP FINISHES.
--------	--

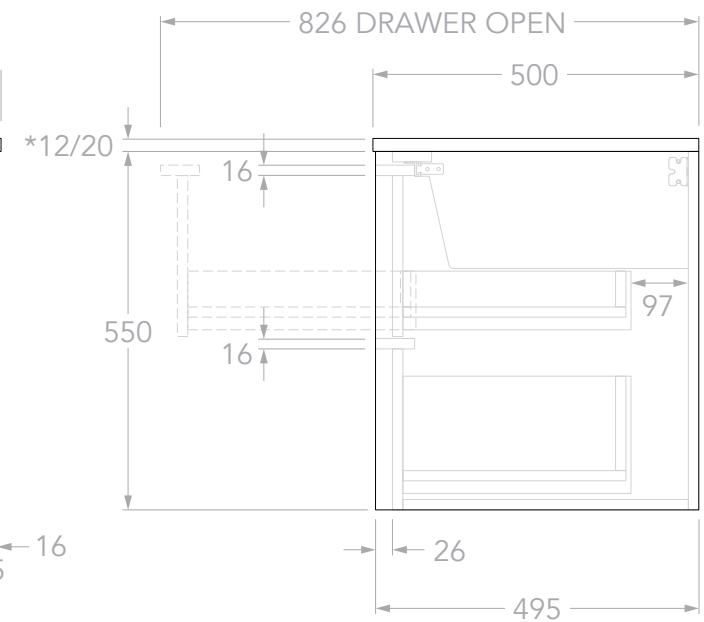
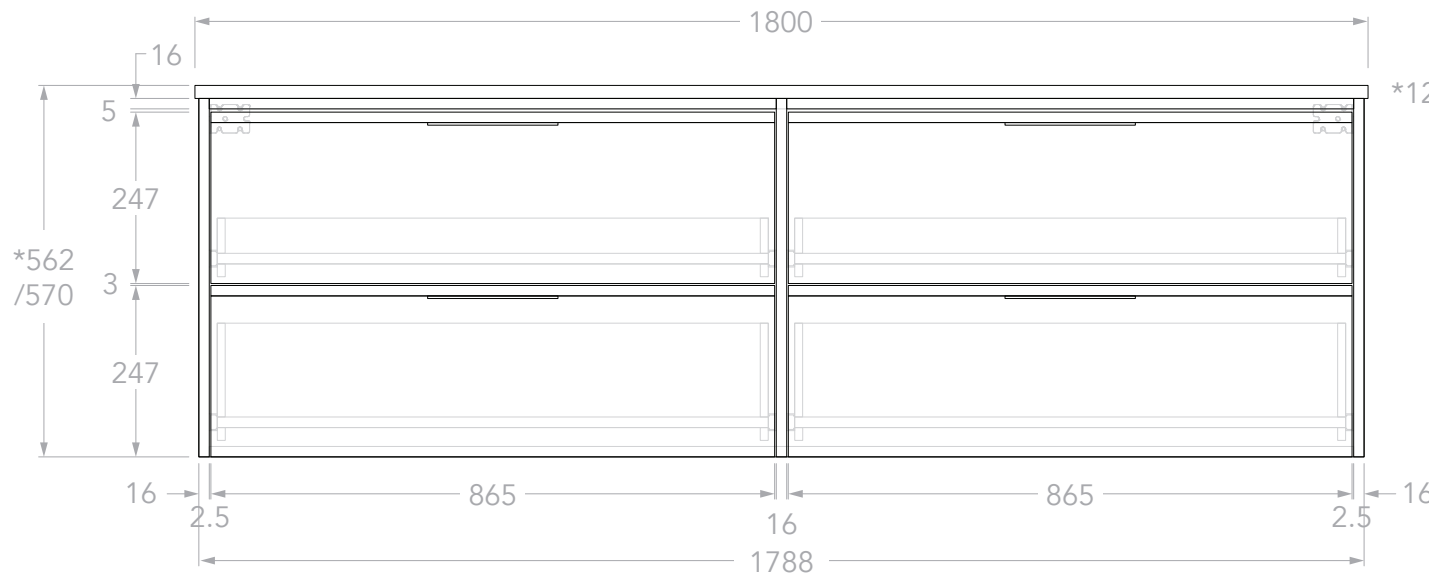
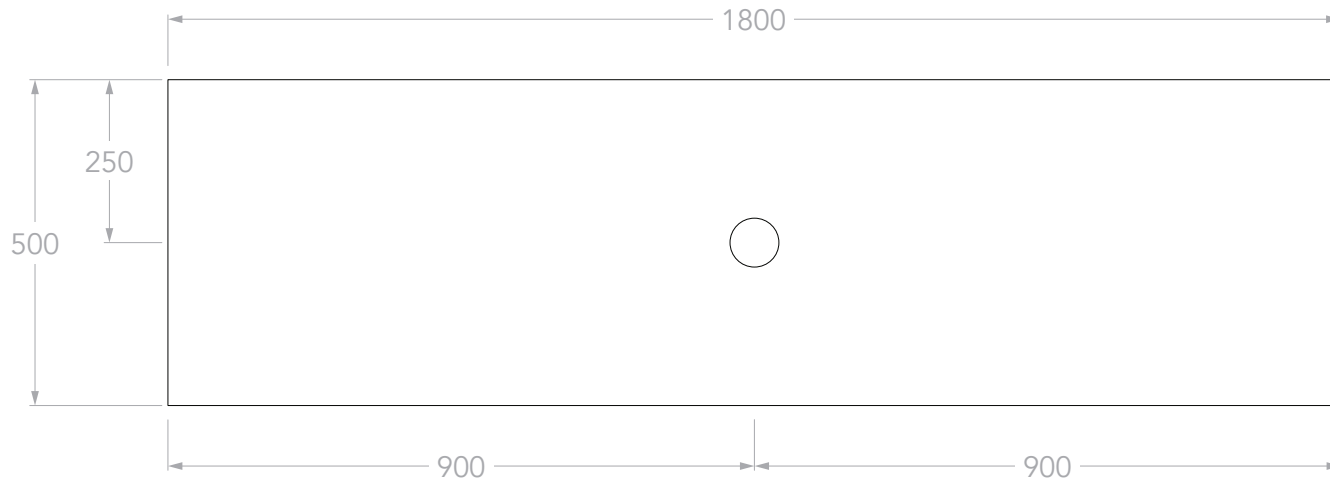

Adp

PRODUCT:	ELI 1800 CENTRE
SIZE:	1800W x 500D x *562/570H
CONFIGURATION:	ALL-DRAWER, WALL HUNG
VERSION: 01	DATE: 25/09/2024

TOP:	40MM BENCHTOP
BASIN POSITION:	CENTRE
CODE:	ELIFAW1800WHC** CODE SUFFIX DEPENDENT ON BENCHTOP MATERIAL SEE BROCHURE OR ADPAUSTRALIA.COM.AU FOR DETAILS

NOTES:	DIMENSIONS ARE NOMINAL. DO NOT DRILL OR ROUGH IN UNTIL YOU HAVE RECEIVED AND MEASURED YOUR VANITY. ALL DIMENSIONS ARE IN MILLIMETRES. DO NOT MEASURE FROM DRAWING. *FOR DURASEIN FINISHES 12MM MATERIAL THICKNESS. 20MM THICKNESS FOR ALL OTHER BENCHTOP FINISHES.
--------	--

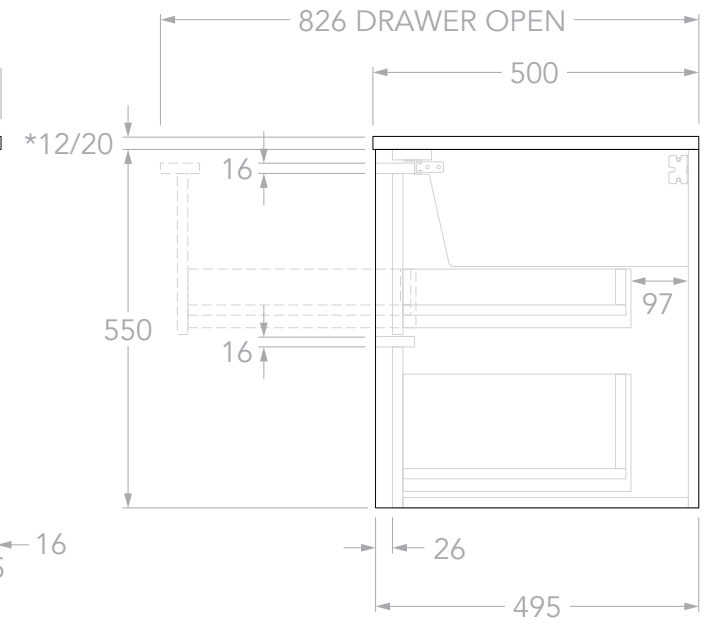
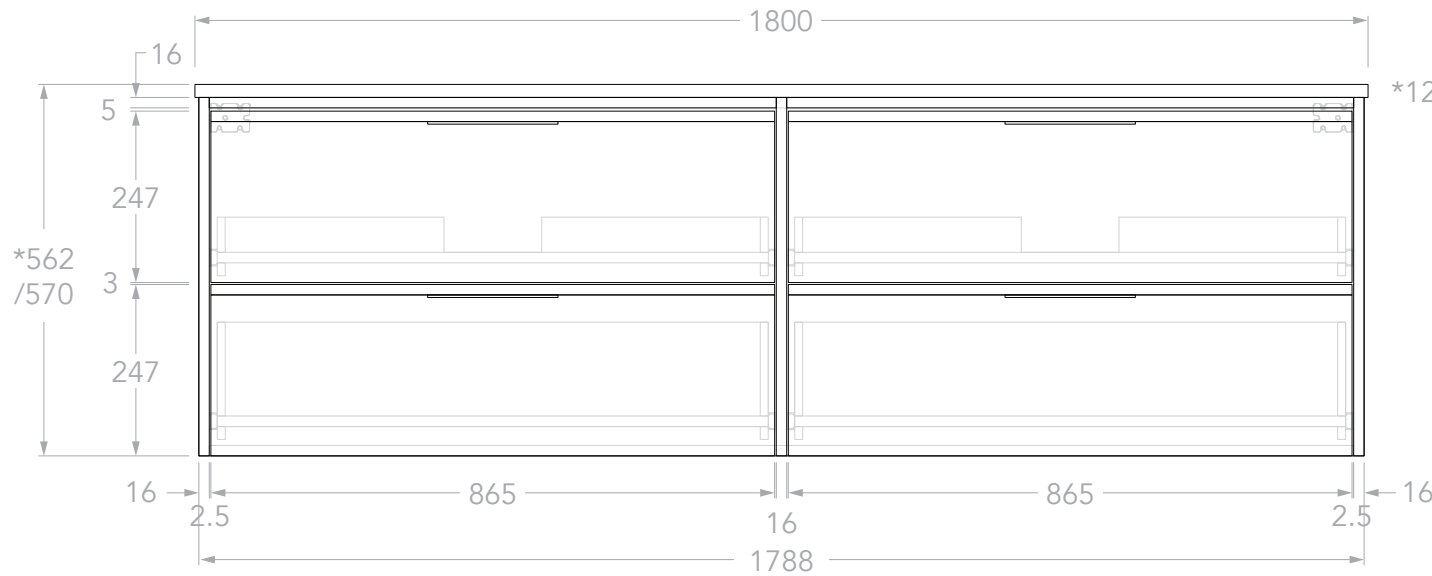
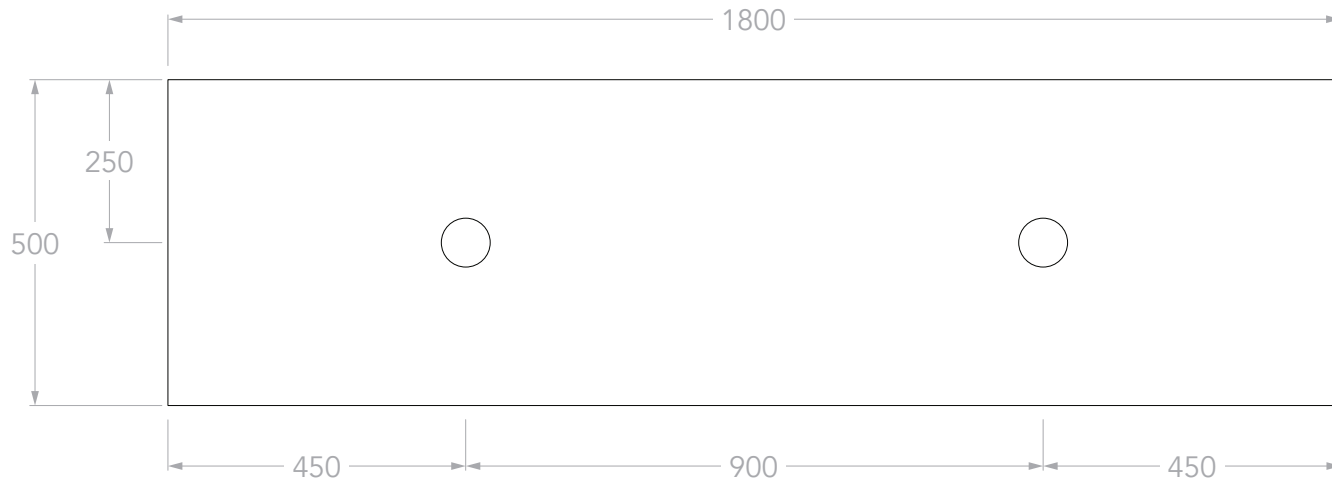

PRODUCT:	ELI 1800 DOUBLE
SIZE:	1800W x 500D x *562/570H
CONFIGURATION:	ALL-DRAWER, WALL HUNG
VERSION: 01	DATE: 25/09/2024

TOP:	40MM BENCHTOP
BASIN POSITION:	DOUBLE
CODE:	ELIFAW1800WHD** CODE SUFFIX DEPENDENT ON BENCHTOP MATERIAL SEE BROCHURE OR ADPAUSTRALIA.COM.AU FOR DETAILS

NOTES:	DIMENSIONS ARE NOMINAL. DO NOT DRILL OR ROUGH IN UNTIL YOU HAVE RECEIVED AND MEASURED YOUR VANITY. ALL DIMENSIONS ARE IN MILLIMETRES. DO NOT MEASURE FROM DRAWING. *FOR DURASEIN FINISHES 12MM MATERIAL THICKNESS. 20MM THICKNESS FOR ALL OTHER BENCHTOP FINISHES.
--------	--

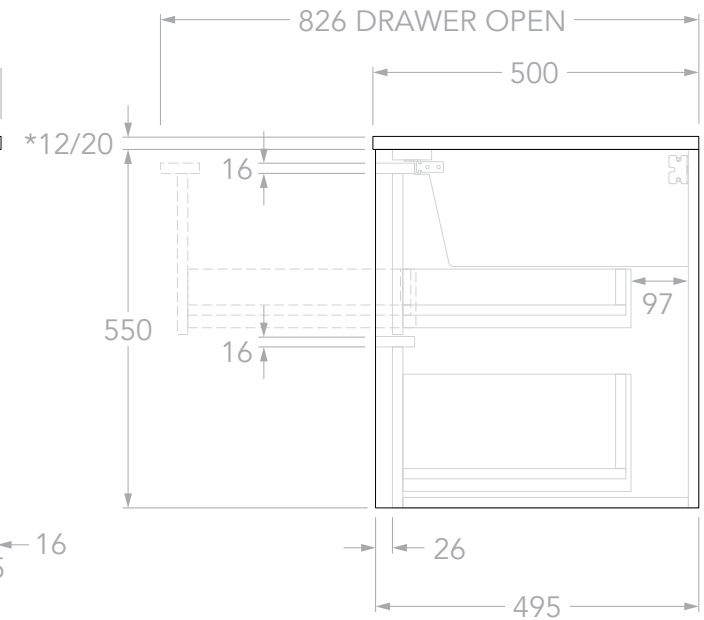
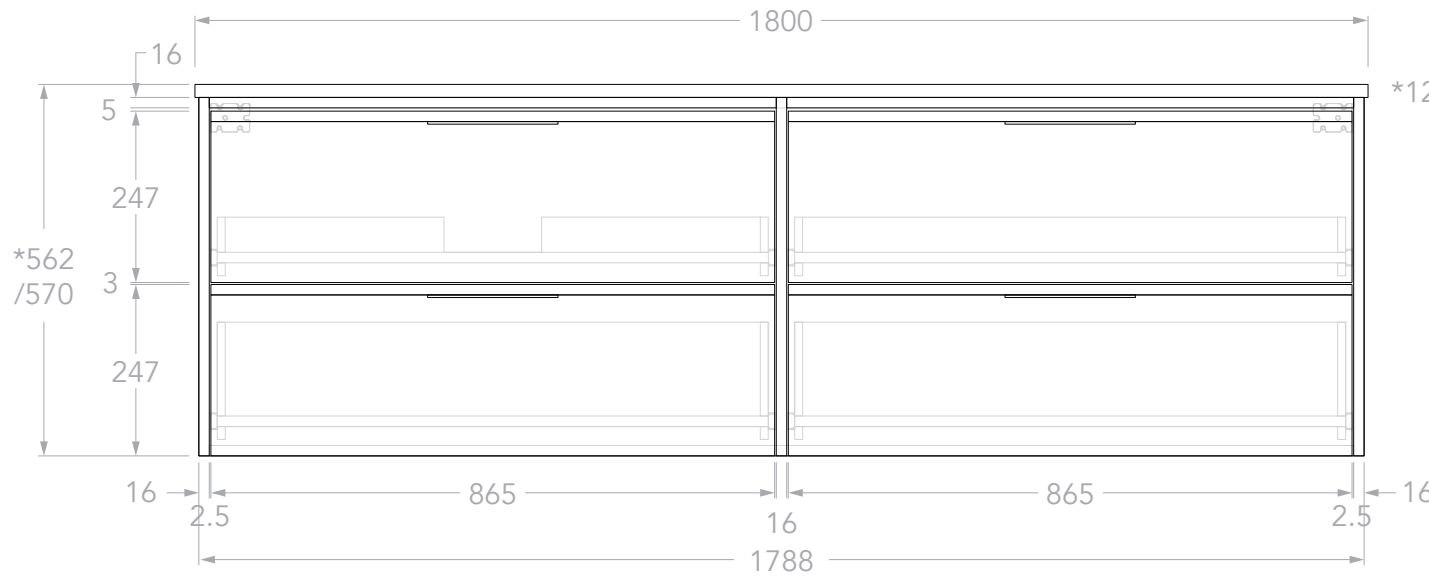
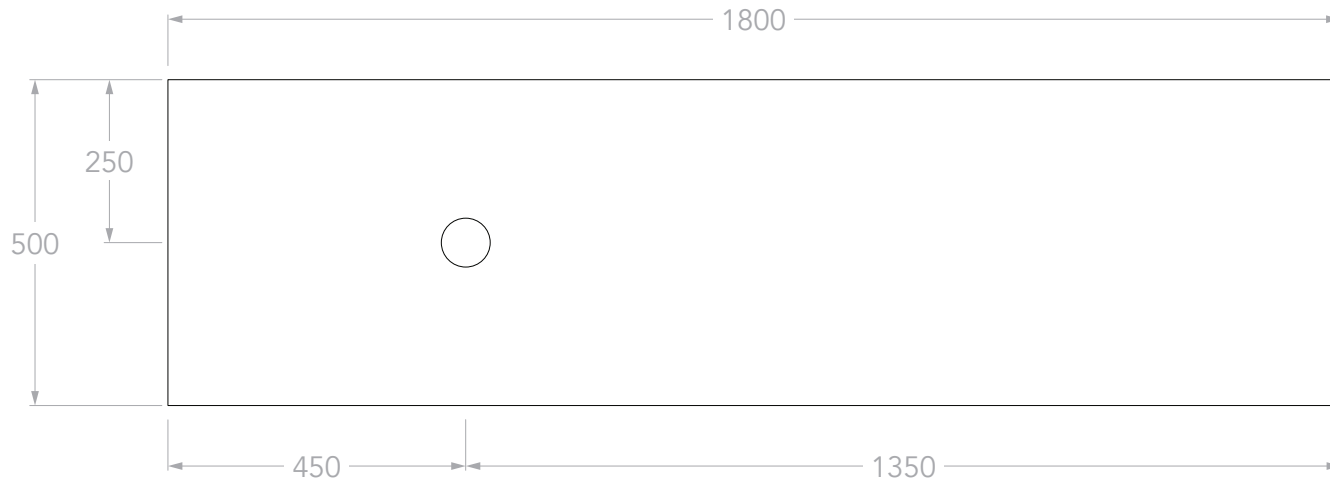

PRODUCT:	ELI 1800 LEFT
SIZE:	1800W x 500D x *562/570H
CONFIGURATION:	ALL-DRAWER, WALL HUNG
VERSION: 01	DATE: 25/09/2024

TOP:	40MM BENCHTOP
BASIN POSITION:	LEFT
CODE:	ELIFAW1800WHL** CODE SUFFIX DEPENDENT ON BENCHTOP MATERIAL SEE BROCHURE OR ADPAUSTRALIA.COM.AU FOR DETAILS

NOTES:	DIMENSIONS ARE NOMINAL. DO NOT DRILL OR ROUGH IN UNTIL YOU HAVE RECEIVED AND MEASURED YOUR VANITY. ALL DIMENSIONS ARE IN MILLIMETRES. DO NOT MEASURE FROM DRAWING. *FOR DURASEIN FINISHES 12MM MATERIAL THICKNESS. 20MM THICKNESS FOR ALL OTHER BENCHTOP FINISHES.
--------	--

